

Outage Data Initiative Test Script

Table of Contents

Table of Contents	2
Table of Figures	4
How to Use This Test Script	5
SoapUI	5
The PubOutages Schema	9
Outage.....	9
ActualPeriod.....	9
EstimatedPeriod.....	10
EstimatedRestorationTime	10
Incident	10
Location.....	11
OutageArea	13
POST Requests	13
Use Case ODI-ADD-MND-MRID (Add Mandatory mRID): A POST Request to Add Outage Data With mRID as an Integer Type	13
Use Case ODI-ADD-MND-RST (Add Mandatory Reported Start Time): A POST Request to Add Outage Data With Missing Reported Start Time	15
Use Case ODI-ADD-MND-SK (Add Mandatory statusKind): A POST Request with Missing StatusKind .	16
Use Case ODI-ADD-ALL (All Fields Present): A POST Request to Add Outage Data With All Fields Present	17
Use Case ODI-ADD-OPT-AP1 (Optional ActualPeriod): A POST Request to add Outage Data With All Fields Present Except Actualperiod	19
Use Case ODI-ADD-OPT-AP2 (ActualPeriod Missing Field): A POST Request to add Outage Data Missing Field From ActualPeriod.....	20
Use Case ODI-ADD-OPT-EP1 (Optional EstimatedPeriod): A POST Request to add Outage Data With All Fields Present Except Estimatedperiod	21
Use Case ODI-ADD-OPT-EP2 (EstimatedPeriod Missing Field): A POST Request to add Outage Data With Missing Field from EstimatedPeriod	22
Use Case ODI-ADD-OPT-ERT1 (Optional EstimatedRestorationTime): A POST Request to add Outage Data With All Fields Present Except EstimatedRestorationTime	23
Use Case ODI-ADD-OPT-ERT2 (EstimatedRestorationTime Missing Field): A POST Request to add Outage Data With Missing Field from EstimatedRestorationTime.....	25

Use Case ODI-ADD-MTO-PP1 (ManyToOne PositionPoints): A POST Request to add Outage Data With Multiple Position Points Provided.....	26
Use Case ODI-ADD-MTO-PP2 (ManyToOne PositionPoints): A POST Request to add Outage Data With Multiple Position Points Provided With Missing Mandatory Field.....	27
Use Case ODI-ADD-MTO-OA1 (ManyToOne OutageAreas): A POST Request to add Outage Data With Multiple Outage Areas Provided.....	29
Use Case ODI-ADD-MTO-OA2 (ManyToOne OutageAreas): A POST Request to add Outage Data With Multiple Outage Areas Provided With Missing Mandatory Field	30
Use Case ODI-ADD-MTO-INC1 (ManyToOne Incidents): A POST Request to add Outage Data With Multiple Incidents Provided.....	31
Use Case ODI-ADD-MTO-INC2 (ManyToOne Incidents): A POST Request to add Outage Data With Multiple Incidents Provided With Missing Field	33
PUT Requests	35
Use Case ODI-UPD-ALL (Update All Fields): A PUT Request Changing Data From ODI-ADD-ALL	35
Use Case ODI-UPD-OPT-AP1 (Update Optional ActualPeriod): A PUT Request to Change ODI-ADD-OPT-AP1 by Adding Actualperiod Data.....	36
Use Case ODI-UPD-OPT-EP1 (Update Optional EstimatedPeriod): A POST Request to Change ODI-ADD-OPT-EP1 by Adding Estimatedperiod Data	37
Use Case ODI-UPD-OPT-ERT1 (Update Optional EstimatedRestorationTime): A PUT Request to Change ODI-ADD-OPT-ERT1 by Adding EstimatedRestorationTime.....	39
Use Case ODI-UPD-MTO-PP1 (Update Multiple PositionPoints): A PUT Request to Change ODI-ADD-MTO-PP1 by Removing Extra PositionPoints	40
Use Case ODI-UPD-MTO-OA1 (Update Multiple OutageAreas): A PUT Request to Change ODI-ADD-MTO-OA1 by Removing Extra OutageAreas	41
Use Case ODI-UPD-MTO-INC1 (Update ManyToOne Incidents): A PUT Request to Change ODI-ADD-MTO-INC1 by Removing Extra Incidents.....	42
PATCH Requests.....	44
Use Case ODI-PATCH-1FIELD (Patch One Field): A PATCH Request to Change One Mislabeled Field from ODI-ADD-ALL	44
Get Requests.....	44
Use Case ODI-GET-ALL (Get All Outages): A GET Request to Retrieve All Outage Data	44
Use Case ODI-GET-ONE (Get Specified Outage): A GET Request to Retrieve Specific Outage Data	44
Use Case ODI-DEL-ONE (Delete Outage): A DELETE Request to Remove Outage Data Created Earlier.	45

Table of Figures

Figure 1: Importing a project in SoapUI	5
Figure 2: Same file structure for this test script in SoapUI	6
Figure 3: Sending a POST message in SoapUI using their REST interface	6
Figure 4: Schema view of "actualPeriod" data type	9
Figure 5: Schema view of "estimatedPeriod" data type	10
Figure 6: Schema view of "estimatedRestorationTime" data type.....	10
Figure 7: Schema view of "Incident" data type.....	11
Figure 8: Schema view of "Location" data type	12
Figure 9: Schema view of "CoordinateSystem" and "PositionPoints" data types	13
Figure 10: Schema view of "OutageArea" data type	13
Figure 11: Setting optional parameters for a RESTful URI in SoapUI	45
Figure 12: View of all added parameters in a RESTful URI in SoapUI	45

This document serves as a reference for the provided SOAP UI use cases to test the outages web service. These use cases are written for a REST service that uses an XML payload.

How to Use This Test Script

These test cases are arranged in a specific pattern. The first test case for each category that has a number at the end (e.g. ODI-ADD-OPT-AP1) should succeed, while the second in the sequence should fail, typically due to a missing mandatory field. In these instances, an error code 400 should be presented due to being unable to validate against the schema. Similarly, all test cases with MND in the title (e.g. ODI-ADD-MND-MRID) should fail and receive some kind of error message by the receiving system.

A SOAP UI file is provided for testing, but if another testing tool such as Postman is desired, the Sample XML folder contains each test case outlined in this document. A brief explanation of how to use the SoapUI tool is described in the following section.

SoapUI

To use these test cases in SoapUI, first download the free software from <https://www.soapui.org>. This is free software that can be used for testing SOAP or RESTful Web Services.

Open SoapUI, select File, and then Import Project.

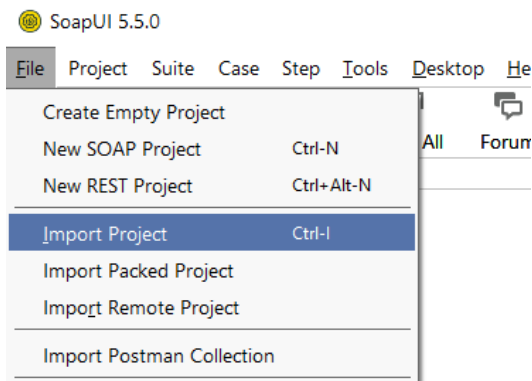

Figure 1: Importing a project in SoapUI

Select the provided SoapUI file, *Outage-Data-soapui-project.xml*. This will open the project for you, and should have a screen similar to the one below.

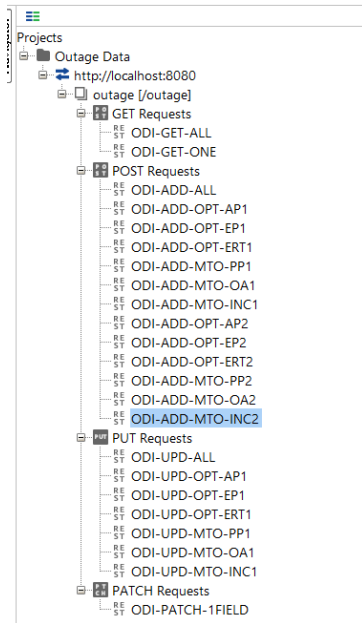

Figure 2: Same file structure for this test script in SoapUI

Where applicable, such as with the POST, PUT, and PATCH requests, the use case XML will be auto-populated and the only adjustment that will need to be made is putting in the proper endpoint address representing the hosted web service.

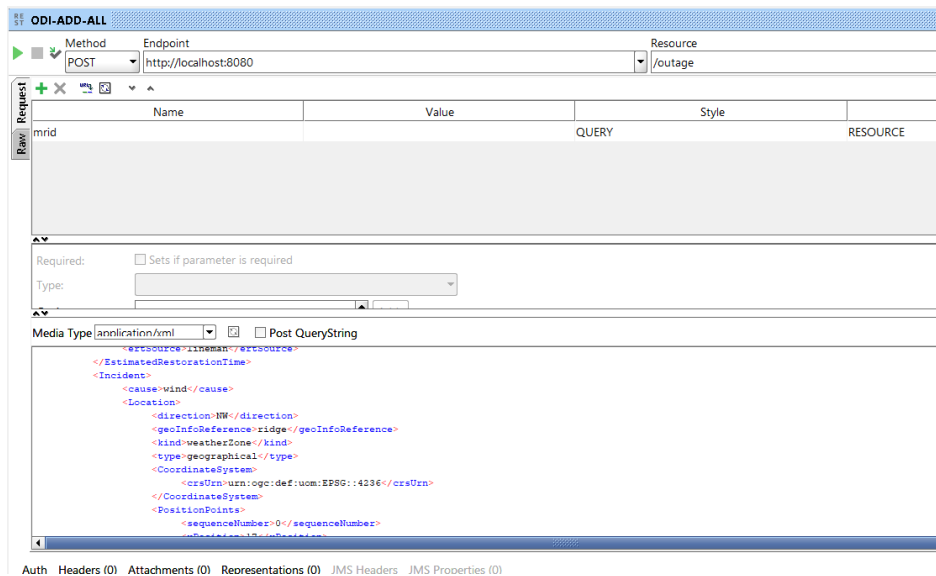

Figure 3: Sending a POST message in SoapUI using their REST interface

In the screenshot above, the only things that will need to be changed are the Endpoint and Resource fields. Once those are set to properly represent the webservice URI, click the green “play” button in the corner of the screen to send the message.

Schema Validation

A key point of interoperability is conforming to the XSDs so that all parties are sending the same type of message. As such it is important that messages conform to the given schema, PubOutages.xsd. It is sufficient if a received or generated XML file passes XML validation and is semantically equivalent, so as a result it's possible that a system may send slightly different messages than the ones shown in this test script. XML namespaces may be assigned alternative prefixes or be defined in other places in the XML document besides the header of the XML document (e.g. within a parent element).

As an example, below are two XML documents that are semantically equivalent as far as XSD validation is concerned.

```
<?xml version="1.0" encoding="UTF-8"?>
<PubOutages xmlns="http://iec.ch/TC57/2014/PubOutages#"
xmlns:xsi="http://www.w3.org/2001/XMLSchema-instance"
xsi:schemaLocation="http://iec.ch/TC57/2014/PubOutages# PubOutages.xsd">
  <Outage>
    <mRID>fc9758b7-d121-4233-b9f0-a6ef288143fa</mRID>
    <cause>auto accident</cause>
    <causeKind>treeDown</causeKind>
    <communityDescriptor>Bellevue</communityDescriptor>
    <customersRestored>5</customersRestored>
    <metersAffected>107</metersAffected>
    <originalCustomersServed>112</originalCustomersServed>
    <originalMetersAffected>112</originalMetersAffected>
    <outageKind>partiallyRestored</outageKind>
    <reportedStartTime>2019-12-17T09:30:47Z</reportedStartTime>
    <statusKind>fieldComplete</statusKind>
    <utilityDisclaimer>none</utilityDisclaimer>
    <actualPeriod>
      <end>2019-12-17T09:30:47Z</end>
      <start>2019-12-17T09:30:47Z</start>
    </actualPeriod>
    <estimatedPeriod>
      <end>2019-12-17T09:30:47Z</end>
      <start>2019-12-17T09:30:47Z</start>
    </estimatedPeriod>
    <EstimatedRestorationTime>
      <confidenceKind>high</confidenceKind>
      <ert>2019-12-17T09:30:47Z</ert>
      <ertSource>control center</ertSource>
    </EstimatedRestorationTime>
    <Incident>
      <cause>wind</cause>
      <Location>
        <direction>NW</direction>
        <geoInfoReference>lake</geoInfoReference>
        <kind>weatherZone</kind>
        <type>geographical</type>
        <CoordinateSystem>
          <crsUrn>EPSG:4326</crsUrn>
        </CoordinateSystem>
        <PositionPoints>
          <sequenceNumber>0</sequenceNumber>
          <xPosition>33</xPosition>
        </PositionPoints>
      </Location>
    </Incident>
  </Outage>
</PubOutages>
```

```
        <yPosition>15</yPosition>
      </PositionPoints>
    </Location>
  </Incident>
  <OutageArea>
    <earliestReportedTime>2019-12-17T09:30:47Z</earliestReportedTime>
    <metersServed>112</metersServed>
    <outageAreaKind>county</outageAreaKind>
  </OutageArea>
</Outage>
</PubOutages>
```

```
<?xml version="1.0" encoding="UTF-8"?>
<ns2:PubOutages xmlns:ns2="http://iec.ch/TC57/2014/PubOutages#"
xmlns:xsi="http://www.w3.org/2001/XMLSchema-instance"
xsi:schemaLocation="http://iec.ch/TC57/2014/PubOutages# PubOutages.xsd">
  <ns2:Outage>
    <ns2:mRID>fc9758b7-d121-4233-b9f0-a6ef288143fa</ns2:mRID>
    <ns2:cause>auto accident</ns2:cause>
    <ns2:causeKind>treeDown</ns2:causeKind>
    <ns2:communityDescriptor>Bellevue</ns2:communityDescriptor>
    <ns2:customersRestored>5</ns2:customersRestored>
    <ns2:metersAffected>107</ns2:metersAffected>
    <ns2:originalCustomersServed>112</ns2:originalCustomersServed>
    <ns2:originalMetersAffected>112</ns2:originalMetersAffected>
    <ns2:outageKind>partiallyRestored</ns2:outageKind>
    <ns2:reportedStartTime>2019-12-17T09:30:47Z</ns2:reportedStartTime>
    <ns2:statusKind>fieldComplete</ns2:statusKind>
    <ns2:utilityDisclaimer>none</ns2:utilityDisclaimer>
    <ns2:actualPeriod>
      <ns2:end>2019-12-17T09:30:47Z</ns2:end>
      <ns2:start>2019-12-17T09:30:47Z</ns2:start>
    </ns2:actualPeriod>
    <ns2:estimatedPeriod>
      <ns2:end>2019-12-17T09:30:47Z</ns2:end>
      <ns2:start>2019-12-17T09:30:47Z</ns2:start>
    </ns2:estimatedPeriod>
    <ns2:EstimatedRestorationTime>
      <ns2:confidenceKind>high</ns2:confidenceKind>
      <ns2:ert>2019-12-17T09:30:47Z</ns2:ert>
      <ns2:ertSource>control center</ns2:ertSource>
    </ns2:EstimatedRestorationTime>
    <ns2:Incident>
      <ns2:cause>wind</ns2:cause>
      <ns2:Location>
        <ns2:direction>NW</ns2:direction>
        <ns2:geoInfoReference>lake</ns2:geoInfoReference>
        <ns2:kind>weatherZone</ns2:kind>
        <ns2:type>geographical</ns2:type>
        <ns2:CoordinateSystem>
          <ns2:crsUrn>EPSG:4326</ns2:crsUrn>
        </ns2:CoordinateSystem>
        <ns2:PositionPoints>
          <ns2:sequenceNumber>0</ns2:sequenceNumber>
```



```

        <ns2:xPosition>33</ns2:xPosition>
        <ns2:yPosition>15</ns2:yPosition>
    </ns2:PositionPoints>
</ns2:Location>
</ns2:Incident>
<ns2:OutageArea>
    <ns2:earliestReportedTime>2019-12-17T09:30:47Z</ns2:earliestReportedTime>
    <ns2:metersServed>112</ns2:metersServed>
    <ns2:outageAreaKind>county</ns2:outageAreaKind>
</ns2:OutageArea>
</ns2:Outage>
</ns2:PubOutages>

```

The PubOutages Schema

This test script is based off of the PubOutages.xsd schema. All messages should be validating against the same schema, and this section is intended to briefly describe key points of subsections of the schema that will be used in this test script.

Outage

There can be ZeroToMany Outages in a PubOutage. Outage itself has many optional fields with the only mandatory fields being its mRID, reportedStartTime, and statusKind. The CIM standard requires the use of a UUID for its mRID, which is enforced by the schema. The standard does not enforce how utilities store this data, so fields such as *actualPeriod* may not even be in use by those who simply wish to delete an outage rather than retain it for record-keeping purposes. As a result, many of these fields are marked optional.

ActualPeriod

The actualPeriod field, used to show when an outage actually starts and ends rather than it was first reported, is optional in the subschema. If invoked, all of actualPeriod's fields become mandatory. Below is a snippet of the schema view of actualPeriod in the PubOutages XSD.

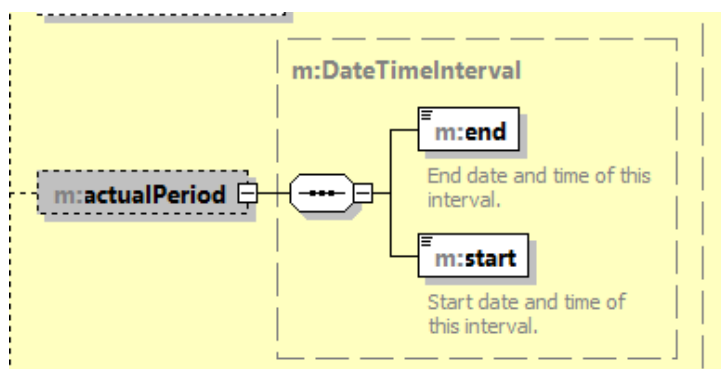

Figure 4: Schema view of "actualPeriod" data type

EstimatedPeriod

The estimatedPeriod field, like actualPeriod, is optional. However, if it used, all fields within are mandatory. The estimatedPeriod schema view is shown below. This field is used to represent estimations for when the outage started and will end.

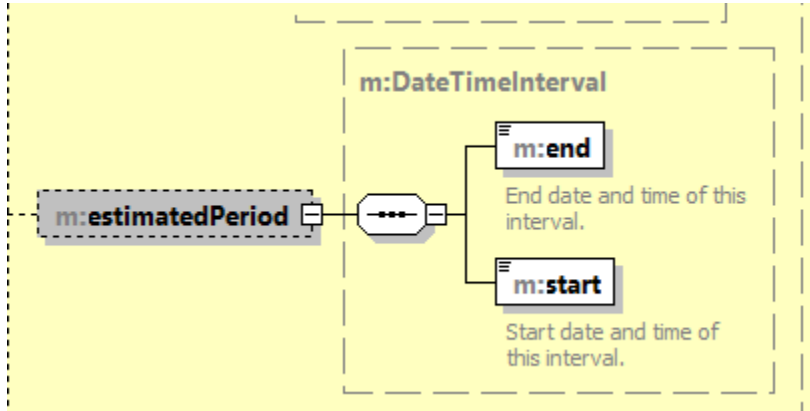

Figure 5: Schema view of "estimatedPeriod" data type

EstimatedRestorationTime

The estimatedRestorationTime field is optional, but once invoked has three mandatory fields that must be provided. The schema view of estimatedRestorationTime from PubOutages.xsd is shown below.

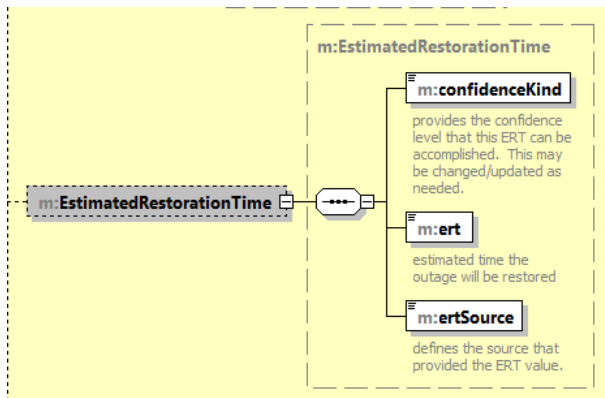

Figure 6: Schema view of "estimatedRestorationTime" data type

Incident

The Incident field is different from the others in that, while it is optional, it has unbounded cardinality. When designing a database to support this schema, it becomes a bit more complicated as the Incident field itself has other fields that possess similar unbounded cardinality. All fields in Incident are required if Incident is supplied.

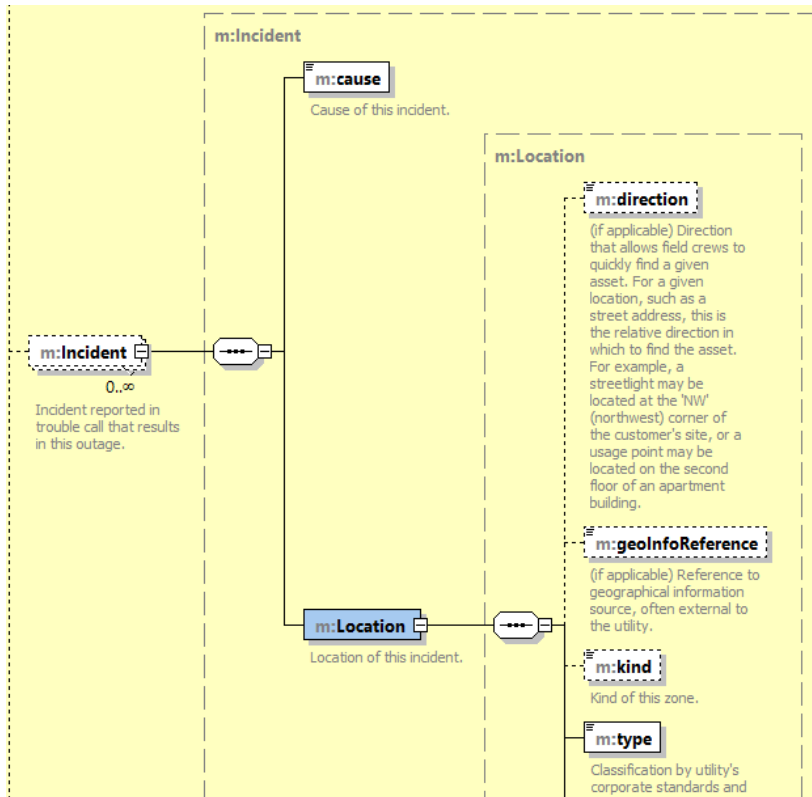

Figure 7: Schema view of "Incident" data type

Location

Location is a mandatory field within Incident that contains its own fields with both OneToOne and OneToMany cardinality. Note that almost all fields are mandatory except for **kind**.

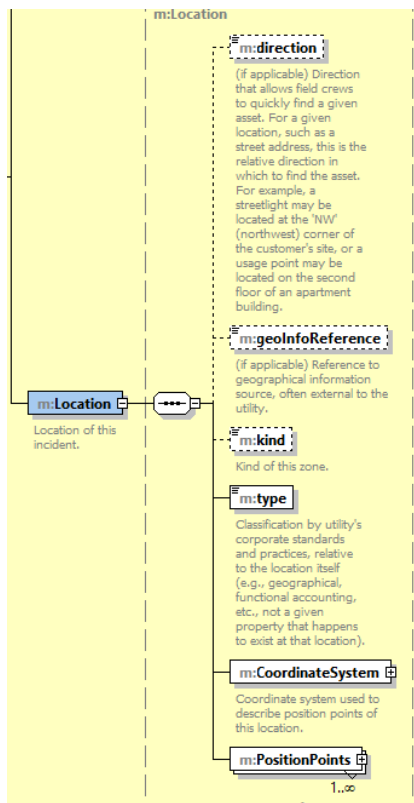

Figure 8: Schema view of "Location" data type

CoordinateSystem

CoordinateSystem is a mandatory field within Location that has only one element of its own, **crsUrn**, which must be provided.

PositionPoints

PositionPoints is a mandatory field within Location that has OneToMany cardinality (i.e. there can be multiple PositionPoints within a given Location). All of PositionPoints' fields are mandatory except for zPosition.

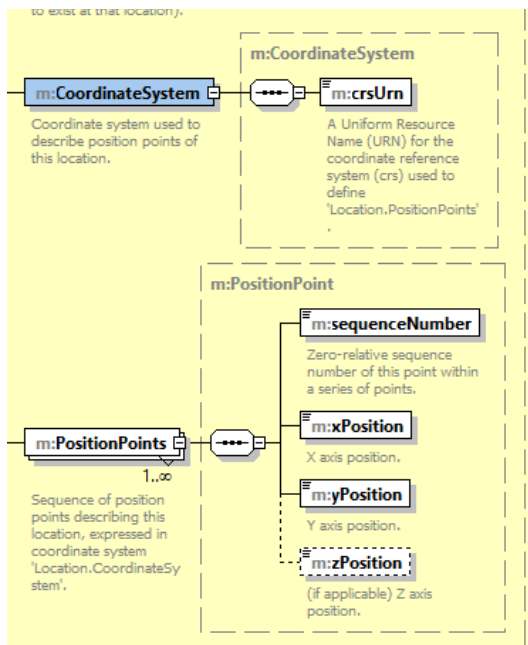

Figure 9: Schema view of "CoordinateSystem" and "PositionPoints" data types

OutageArea

OutageArea is an optional field with ZeroToMany cardinality and three mandatory fields. Although outageArea itself is optional, if it is used then all three of its subelements must be filled. Below is a picture of the schema representation of outageArea.

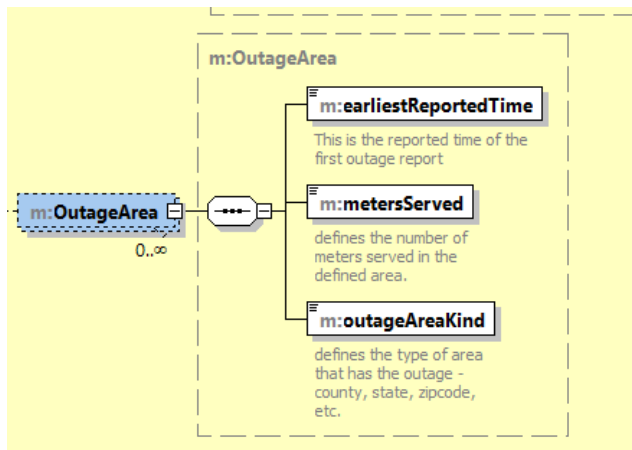

Figure 10: Schema view of "OutageArea" data type

POST Requests

Use Case ODI-ADD-MND-MRID (Add Mandatory mRID): A POST Request to Add Outage Data With mRID as an Integer Type

As per CIM conventions, mRIDs are of a UUID type rather than an integer. Not only does this provide global uniqueness, but it allows for easier exchange of data between two different utilities as it should be immediately clear what outage is being referred to when using a UUID-type for the mRID. However, if both are using auto-incremented integer values, it's possible that two different outages for two different utilities could possess the same mRID. In the following test case, the system should reject the creation of this outage as its mRID is not a UUID.

Result Expectation: Message should fail with error code due to incorrect format for attribute *mRID*.

```
<?xml version="1.0" encoding="UTF-8"?>
<!--Sample XML file generated by XMLSpy v2018 (x64) (http://www.altova.com)-->
<PubOutages xmlns="http://iec.ch/TC57/2014/PubOutages#"
xmlns:xsi="http://www.w3.org/2001/XMLSchema-instance"
xsi:schemaLocation="http://iec.ch/TC57/2014/PubOutages# PubOutages.xsd">
  <Outage>
    <mRID>93018</mRID>
    <cause>weather</cause>
    <causeKind>treeDown</causeKind>
    <communityDescriptor>Karns</communityDescriptor>
    <customersRestored>3</customersRestored>
    <metersAffected>12</metersAffected>
    <originalCustomersServed>12</originalCustomersServed>
    <originalMetersAffected>12</originalMetersAffected>
    <outageKind>partiallyRestored</outageKind>
    <reportedStartTime>2019-12-17T09:30:47Z</reportedStartTime>
    <statusKind>fieldComplete</statusKind>
    <utilityDisclaimer>none</utilityDisclaimer>
    <actualPeriod>
      <end>2019-12-17T09:30:47Z</end>
      <start>2019-12-17T09:30:47Z</start>
    </actualPeriod>
    <estimatedPeriod>
      <end>2019-12-17T09:30:47Z</end>
      <start>2019-12-17T09:30:47Z</start>
    </estimatedPeriod>
    <EstimatedRestorationTime>
      <confidenceKind>high</confidenceKind>
      <ert>2019-12-17T09:30:47Z</ert>
      <ertSource>lineman</ertSource>
    </EstimatedRestorationTime>
    <Incident>
      <cause>wind</cause>
      <Location>
        <direction>NW</direction>
        <geoInfoReference>ridge</geoInfoReference>
        <kind>weatherZone</kind>
        <type>geographical</type>
        <CoordinateSystem>
          <crsUrn>EPSG:4326</crsUrn>
        </CoordinateSystem>
        <PositionPoints>
          <sequenceNumber>0</sequenceNumber>
          <xPosition>17</xPosition>
          <yPosition>31</yPosition>
        </PositionPoints>
      </Location>
    </Incident>
  </Outage>
</PubOutages>
```

```

        </PositionPoints>
    </Location>
</Incident>
<OutageArea>
    <earliestReportedTime>2019-12-
17T09:30:47Z</earliestReportedTime>
    <metersServed>12</metersServed>
    <outageAreaKind>county</outageAreaKind>
</OutageArea>
</Outage>
</PubOutages>

```

Use Case ODI-ADD-MND-RST (Add Mandatory Reported Start Time): A POST Request to Add Outage Data With Missing Reported Start Time

Reported Start Time is a mandatory attribute of the PubOutages schema. As a result, any message that's missing the reported start time should be met with an error message. Should it later be discovered that the actual start time differs from what is initially reported, this can be entered under the **actualPeriod** element.

Result Expectation: Message should fail with error code due to missing mandatory attribute *reportedStartTime*.

```

<?xml version="1.0" encoding="UTF-8"?>
<!--Sample XML file generated by XMLSpy v2018 (x64) (http://www.altova.com)-->
<PubOutages xmlns="http://iec.ch/TC57/2014/PubOutages#"
xmlns:xsi="http://www.w3.org/2001/XMLSchema-instance"
xsi:schemaLocation="http://iec.ch/TC57/2014/PubOutages# PubOutages.xsd">
    <Outage>
        <mRID>3fbbc649-3e42-401b-bbbc-1ab1a1bcbbbe</mRID>
        <cause>weather</cause>
        <causeKind>treeDown</causeKind>
        <communityDescriptor>Karns</communityDescriptor>
        <customersRestored>3</customersRestored>
        <metersAffected>12</metersAffected>
        <originalCustomersServed>12</originalCustomersServed>
        <originalMetersAffected>12</originalMetersAffected>
        <outageKind>partiallyRestored</outageKind>
        <statusKind>fieldComplete</statusKind>
        <utilityDisclaimer>none</utilityDisclaimer>
        <actualPeriod>
            <end>2019-12-17T09:30:47Z</end>
            <start>2019-12-17T09:30:47Z</start>
        </actualPeriod>
        <estimatedPeriod>
            <end>2019-12-17T09:30:47Z</end>
            <start>2019-12-17T09:30:47Z</start>
        </estimatedPeriod>
        <EstimatedRestorationTime>
            <confidenceKind>high</confidenceKind>
            <ert>2019-12-17T09:30:47Z</ert>

```

```

        <ertSource>lineman</ertSource>
    </EstimatedRestorationTime>
    <Incident>
        <cause>wind</cause>
        <Location>
            <direction>NW</direction>
            <geoInfoReference>ridge</geoInfoReference>
            <kind>weatherZone</kind>
            <type>geographical</type>
            <CoordinateSystem>
                <crsUrn>EPSG:4326</crsUrn>
            </CoordinateSystem>
            <PositionPoints>
                <sequenceNumber>0</sequenceNumber>
                <xPosition>17</xPosition>
                <yPosition>31</yPosition>
            </PositionPoints>
        </Location>
    </Incident>
    <OutageArea>
        <earliestReportedTime>2019-12-
17T09:30:47Z</earliestReportedTime>
        <metersServed>12</metersServed>
        <outageAreaKind>county</outageAreaKind>
    </OutageArea>
</Outage>
</PubOutages>

```

Use Case ODI-ADD-MND-SK (Add Mandatory statusKind): A POST Request with Missing StatusKind

In the PubOutage schema, **statusKind** is a mandatory element that should always have some value attached to it, whether it's assigned, enroute, awaitingCrewAssignment, or fieldComplete.

Result Expectation: Message should fail with error code due to missing mandatory attribute *statusKind*.

```

<?xml version="1.0" encoding="UTF-8"?>
<!--Sample XML file generated by XMLSpy v2018 (x64) (http://www.altova.com)-->
<PubOutages xmlns="http://iec.ch/TC57/2014/PubOutages#"
xmlns:xsi="http://www.w3.org/2001/XMLSchema-instance"
xsi:schemaLocation="http://iec.ch/TC57/2014/PubOutages# PubOutages.xsd">
    <Outage>
        <mRID>3fbbc649-3e42-401b-bbbc-1ab1a1bcbbbe</mRID>
        <cause>weather</cause>
        <causeKind>treeDown</causeKind>
        <communityDescriptor>Karns</communityDescriptor>
        <customersRestored>3</customersRestored>
        <metersAffected>12</metersAffected>
        <originalCustomersServed>12</originalCustomersServed>
        <originalMetersAffected>12</originalMetersAffected>
        <outageKind>partiallyRestored</outageKind>
    </Outage>
</PubOutages>

```



```

<utilityDisclaimer>none</utilityDisclaimer>
<actualPeriod>
  <end>2019-12-17T09:30:47Z</end>
  <start>2019-12-17T09:30:47Z</start>
</actualPeriod>
<estimatedPeriod>
  <end>2019-12-17T09:30:47Z</end>
  <start>2019-12-17T09:30:47Z</start>
</estimatedPeriod>
<EstimatedRestorationTime>
  <confidenceKind>high</confidenceKind>
  <ert>2019-12-17T09:30:47Z</ert>
  <ertSource>lineman</ertSource>
</EstimatedRestorationTime>
<Incident>
  <cause>wind</cause>
  <Location>
    <direction>NW</direction>
    <geoInfoReference>ridge</geoInfoReference>
    <kind>weatherZone</kind>
    <type>geographical</type>
    <CoordinateSystem>
      <crsUrn>EPSG:4326</crsUrn>
    </CoordinateSystem>
    <PositionPoints>
      <sequenceNumber>0</sequenceNumber>
      <xPosition>17</xPosition>
      <yPosition>31</yPosition>
    </PositionPoints>
  </Location>
</Incident>
<OutageArea>
  <earliestReportedTime>2019-12-
17T09:30:47Z</earliestReportedTime>
  <metersServed>12</metersServed>
  <outageAreaKind>county</outageAreaKind>
</OutageArea>
</Outage>
</PubOutages>

```

Use Case ODI-ADD-ALL (All Fields Present): A POST Request to Add Outage Data With All Fields Present

This use case adds new Outage data that fills all possible fields for an outage. Note that this test case does not add multiples of unbounded fields such as PositionPoints, OutageArea, etc. The XML for this request is shown below.

Result Expectation: Outage message is processed successfully.

```

<?xml version="1.0" encoding="UTF-8"?>
<!--Sample XML file generated by XMLSpy v2018 (x64) (http://www.altova.com)-->

```

```
<PubOutages xmlns="http://iec.ch/TC57/2014/PubOutages#"
xmlns:xsi="http://www.w3.org/2001/XMLSchema-instance"
xsi:schemaLocation="http://iec.ch/TC57/2014/PubOutages# PubOutages.xsd">
  <Outage>
    <mRID>3fbbc649-3e42-401b-bbbc-1ab1a1bcbbbe</mRID>
    <cause>weather</cause>
    <causeKind>treeDown</causeKind>
    <communityDescriptor>Karns</communityDescriptor>
    <customersRestored>3</customersRestored>
    <metersAffected>12</metersAffected>
    <originalCustomersServed>12</originalCustomersServed>
    <originalMetersAffected>12</originalMetersAffected>
    <outageKind>partiallyRestored</outageKind>
    <reportedStartTime>2019-12-17T09:30:47Z</reportedStartTime>
    <statusKind>fieldComplete</statusKind>
    <utilityDisclaimer>none</utilityDisclaimer>
    <actualPeriod>
      <end>2019-12-17T09:30:47Z</end>
      <start>2019-12-17T09:30:47Z</start>
    </actualPeriod>
    <estimatedPeriod>
      <end>2019-12-17T09:30:47Z</end>
      <start>2019-12-17T09:30:47Z</start>
    </estimatedPeriod>
    <EstimatedRestorationTime>
      <confidenceKind>high</confidenceKind>
      <ert>2019-12-17T09:30:47Z</ert>
      <ertSource>lineman</ertSource>
    </EstimatedRestorationTime>
    <Incident>
      <cause>wind</cause>
      <Location>
        <direction>NW</direction>
        <geoInfoReference>ridge</geoInfoReference>
        <kind>weatherZone</kind>
        <type>geographical</type>
        <CoordinateSystem>
          <crsUrn>EPSG:4326</crsUrn>
        </CoordinateSystem>
        <PositionPoints>
          <sequenceNumber>0</sequenceNumber>
          <xPosition>17</xPosition>
          <yPosition>31</yPosition>
        </PositionPoints>
      </Location>
    </Incident>
    <OutageArea>
      <earliestReportedTime>2019-12-17T09:30:47Z</earliestReportedTime>
      <metersServed>12</metersServed>
      <outageAreaKind>county</outageAreaKind>
    </OutageArea>
  </Outage>
</PubOutages>
```

Use Case ODI-ADD-OPT-AP1 (Optional ActualPeriod): A POST Request to add Outage Data With All Fields Present Except Actualperiod

This use case is a more typical POST message in that it is missing the *actualPeriod* element. Since the *actualPeriod* is more likely to be added via PUT or PATCH in REST, or as a change in the CIM SOAP standard, most messages should be missing the *actualPeriod* element when first created.

Result Expectation: Message should post successfully with all fields present except for *actualPeriod*.

```
<?xml version="1.0" encoding="UTF-8"?>
<PubOutages xmlns="http://iec.ch/TC57/2014/PubOutages#"
xmlns:xsi="http://www.w3.org/2001/XMLSchema-instance"
xsi:schemaLocation="http://iec.ch/TC57/2014/PubOutages# PubOutages.xsd">
  <Outage>
    <mRID>fc9758b7-d121-4233-b9f0-a6ef288143fa</mRID>
    <cause>auto accident</cause>
    <causeKind>treeDown</causeKind>
    <communityDescriptor>Bellevue</communityDescriptor>
    <customersRestored>5</customersRestored>
    <metersAffected>107</metersAffected>
    <originalCustomersServed>112</originalCustomersServed>
    <originalMetersAffected>112</originalMetersAffected>
    <outageKind>partiallyRestored</outageKind>
    <reportedStartTime>2019-12-17T09:30:47Z</reportedStartTime>
    <statusKind>fieldComplete</statusKind>
    <utilityDisclaimer>none</utilityDisclaimer>
    <estimatedPeriod>
      <end>2019-12-17T09:30:47Z</end>
      <start>2019-12-17T09:30:47Z</start>
    </estimatedPeriod>
    <EstimatedRestorationTime>
      <confidenceKind>high</confidenceKind>
      <ert>2019-12-17T09:30:47Z</ert>
      <ertSource>control center</ertSource>
    </EstimatedRestorationTime>
    <Incident>
      <cause>wind</cause>
      <Location>
        <direction>NW</direction>
        <geoInfoReference>lake</geoInfoReference>
        <kind>weatherZone</kind>
        <type>geographical</type>
        <CoordinateSystem>
          <crsUrn>EPSG:4326</crsUrn>
        </CoordinateSystem>
        <PositionPoints>
          <sequenceNumber>0</sequenceNumber>
          <xPosition>33</xPosition>
          <yPosition>15</yPosition>
        </PositionPoints>
      </Location>
    </Incident>
    <OutageArea>
```

```
<earliestReportedTime>2019-12-17T09:30:47Z</earliestReportedTime>
<metersServed>112</metersServed>
<outageAreaKind>county</outageAreaKind>
</OutageArea>
</Outage>
</PubOutages>
```

Use Case ODI-ADD-OPT-AP2 (ActualPeriod Missing Field): A POST Request to add Outage Data Missing Field From ActualPeriod

In this use case, *actualPeriod* is missing a mandatory field, *end*. *ActualPeriod* should be used to represent the actual start and end time of the outage and is thus most likely to be added through a PUT or PATCH request when using REST, or a *change* message if implemented using the CIM SOAP standard.

Result Expectation: Message should fail with error code due to mandatory field *end* missing from *actualPeriod*.

```
<?xml version="1.0" encoding="UTF-8"?>
<PubOutages xmlns="http://iec.ch/TC57/2014/PubOutages#"
xmlns:xsi="http://www.w3.org/2001/XMLSchema-instance"
xsi:schemaLocation="http://iec.ch/TC57/2014/PubOutages# PubOutages.xsd">
  <Outage>
    <mRID>956c434f-0281-4748-ad27-e1c708ce8800</mRID>
    <cause>auto accident</cause>
    <causeKind>treeDown</causeKind>
    <communityDescriptor>Bellevue</communityDescriptor>
    <customersRestored>5</customersRestored>
    <metersAffected>107</metersAffected>
    <originalCustomersServed>112</originalCustomersServed>
    <originalMetersAffected>112</originalMetersAffected>
    <outageKind>partiallyRestored</outageKind>
    <reportedStartTime>2019-12-17T09:30:47Z</reportedStartTime>
    <statusKind>fieldComplete</statusKind>
    <utilityDisclaimer>none</utilityDisclaimer>
    <actualPeriod>
      <start>2019-12-17T09:30:47Z</start>
    </actualPeriod>
    <estimatedPeriod>
      <end>2019-12-17T09:30:47Z</end>
      <start>2019-12-17T09:30:47Z</start>
    </estimatedPeriod>
    <EstimatedRestorationTime>
      <confidenceKind>high</confidenceKind>
      <ert>2019-12-17T09:30:47Z</ert>
      <ertSource>control center</ertSource>
    </EstimatedRestorationTime>
    <Incident>
      <cause>wind</cause>
      <Location>
        <direction>NW</direction>
        <geoInfoReference>lake</geoInfoReference>
```

```

    <kind>weatherZone</kind>
    <type>geographical</type>
    <CoordinateSystem>
      <crsUrn>EPSG:4326</crsUrn>
    </CoordinateSystem>
    <PositionPoints>
      <sequenceNumber>0</sequenceNumber>
      <xPosition>33</xPosition>
      <yPosition>15</yPosition>
    </PositionPoints>
  </Location>
</Incident>
<OutageArea>
  <earliestReportedTime>2019-12-17T09:30:47Z</earliestReportedTime>
  <metersServed>112</metersServed>
  <outageAreaKind>county</outageAreaKind>
</OutageArea>
</Outage>
</PubOutages>

```

Use Case ODI-ADD-OPT-EP1 (Optional EstimatedPeriod): A POST Request to add Outage Data With All Fields Present Except Estimatedperiod

In this use case, the optional *estimatedPeriod* is missing from the initial POST request. Many utilities may opt out of providing information about estimated start and end times of outages and thus it's likely a POST request without that information could be sent.

Result Expectation: Outage message is processed successfully without *estimatedPeriod* attribute.

```

<?xml version="1.0" encoding="UTF-8"?>
<PubOutages xmlns="http://iec.ch/TC57/2014/PubOutages#"
xmlns:xsi="http://www.w3.org/2001/XMLSchema-instance"
xsi:schemaLocation="http://iec.ch/TC57/2014/PubOutages# PubOutages.xsd">
  <Outage>
    <mRID>fd532f2d-37d8-423a-a08e-8f9e4c4e6283</mRID>
    <cause>animal</cause>
    <causeKind>poleDown</causeKind>
    <communityDescriptor>Belltown</communityDescriptor>
    <customersRestored>177</customersRestored>
    <metersAffected>835</metersAffected>
    <originalCustomersServed>1012</originalCustomersServed>
    <originalMetersAffected>1012</originalMetersAffected>
    <outageKind>partiallyRestored</outageKind>
    <reportedStartTime>2019-12-17T09:30:47Z</reportedStartTime>
    <statusKind>arrived</statusKind>
    <utilityDisclaimer>none</utilityDisclaimer>
    <actualPeriod>
      <end>2019-12-17T09:30:47Z</end>
      <start>2019-12-17T09:30:47Z</start>
    </actualPeriod>
    <EstimatedRestorationTime>
      <confidenceKind>high</confidenceKind>

```

```

    <ert>2019-12-17T09:30:47Z</ert>
    <ertSource>control center</ertSource>
  </EstimatedRestorationTime>
  <Incident>
    <cause>wind</cause>
    <Location>
      <direction>W</direction>
      <geoInfoReference>park</geoInfoReference>
      <kind>weatherZone</kind>
      <type>geographical</type>
      <CoordinateSystem>
        <crsUrn>EPSG:4326</crsUrn>
      </CoordinateSystem>
      <PositionPoints>
        <sequenceNumber>0</sequenceNumber>
        <xPosition>15</xPosition>
        <yPosition>66</yPosition>
      </PositionPoints>
    </Location>
  </Incident>
  <OutageArea>
    <earliestReportedTime>2019-12-17T09:30:47Z</earliestReportedTime>
    <metersServed>1012</metersServed>
    <outageAreaKind>county</outageAreaKind>
  </OutageArea>
</Outage>
</PubOutages>

```

Use Case ODI-ADD-OPT-EP2 (EstimatedPeriod Missing Field): A POST Request to add Outage Data With Missing Field from EstimatedPeriod

In this test case, estimatedPeriod is missing a mandatory field, *end*. When sending information regarded the *estimatedPeriod*, both a start and end time must be provided.

Result Expectation: Message should fail with error code due to missing mandatory attribute *end* for *estimatedPeriod*.

```

<?xml version="1.0" encoding="UTF-8"?>
<PubOutages xmlns="http://iec.ch/TC57/2014/PubOutages#"
xmlns:xsi="http://www.w3.org/2001/XMLSchema-instance"
xsi:schemaLocation="http://iec.ch/TC57/2014/PubOutages# PubOutages.xsd">
  <Outage>
    <mRID>b4babad-d-4e92-46c7-8659-a497061c5ff3</mRID>
    <cause>animal</cause>
    <causeKind>poleDown</causeKind>
    <communityDescriptor>Belltown</communityDescriptor>
    <customersRestored>177</customersRestored>
    <metersAffected>835</metersAffected>
    <originalCustomersServed>1012</originalCustomersServed>
    <originalMetersAffected>1012</originalMetersAffected>

```

```

<outageKind>partiallyRestored</outageKind>
<reportedStartTime>2019-12-17T09:30:47Z</reportedStartTime>
<statusKind>arrived</statusKind>
<utilityDisclaimer>none</utilityDisclaimer>
<actualPeriod>
  <end>2019-12-17T09:30:47Z</end>
  <start>2019-12-17T09:30:47Z</start>
</actualPeriod>
<estimatedPeriod>
  <start>2019-12-17T09:30:47Z</start>
</estimatedPeriod>
<EstimatedRestorationTime>
  <confidenceKind>high</confidenceKind>
  <ert>2019-12-17T09:30:47Z</ert>
  <ertSource>control center</ertSource>
</EstimatedRestorationTime>
<Incident>
  <cause>wind</cause>
  <Location>
    <direction>W</direction>
    <geoInfoReference>park</geoInfoReference>
    <kind>weatherZone</kind>
    <type>geographical</type>
    <CoordinateSystem>
      <crsUrn>EPSG:4326</crsUrn>
    </CoordinateSystem>
    <PositionPoints>
      <sequenceNumber>0</sequenceNumber>
      <xPosition>15</xPosition>
      <yPosition>66</yPosition>
    </PositionPoints>
  </Location>
</Incident>
<OutageArea>
  <earliestReportedTime>2019-12-17T09:30:47Z</earliestReportedTime>
  <metersServed>1012</metersServed>
  <outageAreaKind>county</outageAreaKind>
</OutageArea>
</Outage>
</PubOutages>

```

Use Case ODI-ADD-OPT-ERT1 (Optional EstimatedRestorationTime): A POST Request to add Outage Data With All Fields Present Except EstimatedRestorationTime

In this use case, *estimatedRestorationTime* is omitted from the initial outage creation. Most utilities may automatically assign an estimated restoration time to each outage. For example, a system may assign an estimated restoration time of 4 hours and then a PATCH or PUT request in REST or change message in the CIM SOAP standard may be sent to update the estimated restoration time as conditions change. In this use case, the *estimatedRestorationTime* attribute is omitted entirely.

Result Expectation: Outage message is processed successfully without *estimatedRestorationTime* attribute.

```
<?xml version="1.0" encoding="UTF-8"?>
<PubOutages xmlns="http://iec.ch/TC57/2014/PubOutages#"
xmlns:xsi="http://www.w3.org/2001/XMLSchema-instance"
xsi:schemaLocation="http://iec.ch/TC57/2014/PubOutages# PubOutages.xsd">
  <Outage>
    <mRID>18ea4e83-296a-4f33-a07c-6fbfa4ec777b</mRID>
    <cause>tree</cause>
    <causeKind>lineDown</causeKind>
    <communityDescriptor>Bainbridge Island</communityDescriptor>
    <customersRestored>17</customersRestored>
    <metersAffected>35</metersAffected>
    <originalCustomersServed>52</originalCustomersServed>
    <originalMetersAffected>52</originalMetersAffected>
    <outageKind>partiallyRestored</outageKind>
    <reportedStartTime>2019-12-17T09:30:47Z</reportedStartTime>
    <statusKind>arrived</statusKind>
    <utilityDisclaimer>none</utilityDisclaimer>
    <actualPeriod>
      <end>2019-12-17T09:30:47Z</end>
      <start>2019-12-17T09:30:47Z</start>
    </actualPeriod>
    <estimatedPeriod>
      <end>2019-12-17T09:30:47Z</end>
      <start>2019-12-17T09:30:47Z</start>
    </estimatedPeriod>
    <Incident>
      <cause>wind</cause>
      <Location>
        <direction>S</direction>
        <geoInfoReference>campground</geoInfoReference>
        <kind>weatherZone</kind>
        <type>geographical</type>
        <CoordinateSystem>
          <crsUrn>EPSG:4326</crsUrn>
        </CoordinateSystem>
        <PositionPoints>
          <sequenceNumber>0</sequenceNumber>
          <xPosition>24</xPosition>
          <yPosition>11</yPosition>
        </PositionPoints>
      </Location>
    </Incident>
    <OutageArea>
      <earliestReportedTime>2019-12-17T09:30:47Z</earliestReportedTime>
      <metersServed>52</metersServed>
      <outageAreaKind>county</outageAreaKind>
    </OutageArea>
  </Outage>
</PubOutages>
```

Use Case ODI-ADD-OPT-ERT2 (EstimatedRestorationTime Missing Field): A POST Request to add Outage Data With Missing Field from EstimatedRestorationTime

In this use case, *estimatedRestorationTime* is provided but it is missing one of its mandatory attributes, *ertSource*. This element can be any string value representing the source of the estimated restoration time. For example, the source could be system provided or it could come from someone out on the field that provided an estimate of how long it would take to restore the outage. Because this estimated restoration time must come from somewhere, this field is mandatory. A typical combination might set *ertSource* as "system" and *confidenceKind* as "high" for example.

Result Expecation: Message should fail to post and be met with an error message due to missing mandatory attribute *ertSource* from the *estimatedRestorationTime* element.

```
<?xml version="1.0" encoding="UTF-8"?>
<PubOutages xmlns="http://iec.ch/TC57/2014/PubOutages#"
xmlns:xsi="http://www.w3.org/2001/XMLSchema-instance"
xsi:schemaLocation="http://iec.ch/TC57/2014/PubOutages# PubOutages.xsd">
  <Outage>
    <mRID>93508e1c-c2ac-45c8-88b4-a9684762b701</mRID>
    <cause>tree</cause>
    <causeKind>lineDown</causeKind>
    <communityDescriptor>Bainbridge Island</communityDescriptor>
    <customersRestored>17</customersRestored>
    <metersAffected>35</metersAffected>
    <originalCustomersServed>52</originalCustomersServed>
    <originalMetersAffected>52</originalMetersAffected>
    <outageKind>partiallyRestored</outageKind>
    <reportedStartTime>2019-12-17T09:30:47Z</reportedStartTime>
    <statusKind>arrived</statusKind>
    <utilityDisclaimer>none</utilityDisclaimer>
    <actualPeriod>
      <end>2019-12-17T09:30:47Z</end>
      <start>2019-12-17T09:30:47Z</start>
    </actualPeriod>
    <estimatedPeriod>
      <end>2019-12-17T09:30:47Z</end>
      <start>2019-12-17T09:30:47Z</start>
    </estimatedPeriod>
    <EstimatedRestorationTime>
      <confidenceKind>high</confidenceKind>
      <ert>2019-12-17T09:30:47Z</ert>
    </EstimatedRestorationTime>
    <Incident>
      <cause>wind</cause>
      <Location>
        <direction>S</direction>
        <geoInfoReference>campground</geoInfoReference>
        <kind>weatherZone</kind>
        <type>geographical</type>
        <CoordinateSystem>
          <crsUrn>EPSG:4326</crsUrn>
        </CoordinateSystem>
      </Location>
    </Incident>
  </Outage>
</PubOutages>
```

```

    <PositionPoints>
      <sequenceNumber>0</sequenceNumber>
      <xPosition>24</xPosition>
      <yPosition>11</yPosition>
    </PositionPoints>
  </Location>
</Incident>
<OutageArea>
  <earliestReportedTime>2019-12-17T09:30:47Z</earliestReportedTime>
  <metersServed>52</metersServed>
  <outageAreaKind>county</outageAreaKind>
</OutageArea>
</Outage>
</PubOutages>

```

Use Case ODI-ADD-MTO-PP1 (ManyToOne PositionPoints): A POST Request to add Outage Data With Multiple Position Points Provided

In this use case, an outage is reported with multiple *PositionPoints* elements to signify three broken poles in the same outage area. The receiving system should be able to process multiple position points for a single outage area.

Result Expectation: Outage message is successfully processed with multiple *PositionPoints* elements. Only showing one of the *PositionPoints* and creating three separate outages or only listing one of the *PositionPoints* for a single outage message is considered a failure.

```

<?xml version="1.0" encoding="UTF-8"?>
<!--Sample XML file generated by XMLSpy v2018 (x64) (http://www.altova.com)-->
<PubOutages xmlns="http://iec.ch/TC57/2014/PubOutages#"
xmlns:xsi="http://www.w3.org/2001/XMLSchema-instance"
xsi:schemaLocation="http://iec.ch/TC57/2014/PubOutages# PubOutages.xsd">
  <Outage>
    <mRID>65c8eee7-1ccc-4229-a03e-18196516ae03</mRID>
    <cause>weather</cause>
    <causeKind>poleDown</causeKind>
    <communityDescriptor>downtown</communityDescriptor>
    <customersRestored>1700</customersRestored>
    <metersAffected>2112</metersAffected>
    <originalCustomersServed>1272</originalCustomersServed>
    <originalMetersAffected>2112</originalMetersAffected>
    <outageKind>partiallyRestored</outageKind>
    <reportedStartTime>2019-12-17T09:30:47Z</reportedStartTime>
    <statusKind>fieldComplete</statusKind>
    <utilityDisclaimer>none</utilityDisclaimer>
    <actualPeriod>
      <end>2019-12-17T09:30:47Z</end>
      <start>2019-12-17T09:30:47Z</start>
    </actualPeriod>
    <estimatedPeriod>
      <end>2019-12-17T09:30:47Z</end>
      <start>2019-12-17T09:30:47Z</start>

```

```

</estimatedPeriod>
<EstimatedRestorationTime>
  <confidenceKind>high</confidenceKind>
  <ert>2019-12-17T09:30:47Z</ert>
  <ertSource>lineman</ertSource>
</EstimatedRestorationTime>
<Incident>
  <cause>wind</cause>
  <Location>
    <direction>NW</direction>
    <geoInfoReference>ridge</geoInfoReference>
    <kind>weatherZone</kind>
    <type>geographical</type>
    <CoordinateSystem>
      <crsUrn>EPSG:4326</crsUrn>
    </CoordinateSystem>
    <PositionPoints>
      <sequenceNumber>0</sequenceNumber>
      <xPosition>17</xPosition>
      <yPosition>42</yPosition>
    </PositionPoints>
    <PositionPoints>
      <sequenceNumber>1</sequenceNumber>
      <xPosition>17</xPosition>
      <yPosition>41</yPosition>
    </PositionPoints>
    <PositionPoints>
      <sequenceNumber>2</sequenceNumber>
      <xPosition>17</xPosition>
      <yPosition>42</yPosition>
    </PositionPoints>
  </Location>
</Incident>
<OutageArea>
  <earliestReportedTime>2019-12-17T09:30:47Z</earliestReportedTime>
  <metersServed>2112</metersServed>
  <outageAreaKind>county</outageAreaKind>
</OutageArea>
</Outage>
</PubOutages>

```

Use Case ODI-ADD-MTO-PP2 (ManyToOne PositionPoints): A POST Request to add Outage Data With Multiple Position Points Provided With Missing Mandatory Field

This use case is mostly the same as ODI-ADD-MTO-PP1, except that one of the mandatory fields, *sequenceNumber*, is missing in one of the *PositionPoints*. Despite the rest of the message being well-formed, this causes the entire message to not validate against the schema. The *sequenceNumber* attribute is used to designate sequence of that *PositionPoint* in a series of *PositionPoints*.

Result Expectation: Message should fail with error code due to missing attribute *sequenceNumber* in one of the *PositionPoints* elements.

```
<?xml version="1.0" encoding="UTF-8"?>
<PubOutages xmlns="http://iec.ch/TC57/2014/PubOutages#"
xmlns:xsi="http://www.w3.org/2001/XMLSchema-instance"
xsi:schemaLocation="http://iec.ch/TC57/2014/PubOutages# PubOutages.xsd">
  <Outage>
    <mRID>da393f1f-1920-4e4d-a74e-b115e3cea4b6</mRID>
    <cause>weather</cause>
    <causeKind>poleDown</causeKind>
    <communityDescriptor>downtown</communityDescriptor>
    <customersRestored>1700</customersRestored>
    <metersAffected>2112</metersAffected>
    <originalCustomersServed>1272</originalCustomersServed>
    <originalMetersAffected>2112</originalMetersAffected>
    <outageKind>partiallyRestored</outageKind>
    <reportedStartTime>2019-12-17T09:30:47Z</reportedStartTime>
    <statusKind>fieldComplete</statusKind>
    <utilityDisclaimer>none</utilityDisclaimer>
    <actualPeriod>
      <end>2019-12-17T09:30:47Z</end>
      <start>2019-12-17T09:30:47Z</start>
    </actualPeriod>
    <estimatedPeriod>
      <end>2019-12-17T09:30:47Z</end>
      <start>2019-12-17T09:30:47Z</start>
    </estimatedPeriod>
    <EstimatedRestorationTime>
      <confidenceKind>high</confidenceKind>
      <ert>2019-12-17T09:30:47Z</ert>
      <ertSource>lineman</ertSource>
    </EstimatedRestorationTime>
    <Incident>
      <cause>wind</cause>
      <Location>
        <direction>NW</direction>
        <geoInfoReference>ridge</geoInfoReference>
        <kind>weatherZone</kind>
        <type>geographical</type>
        <CoordinateSystem>
          <crsUrn>EPSG:4326</crsUrn>
        </CoordinateSystem>
        <PositionPoints>
          <sequenceNumber>0</sequenceNumber>
          <xPosition>17</xPosition>
          <yPosition>42</yPosition>
        </PositionPoints>
        <PositionPoints>
          <sequenceNumber>1</sequenceNumber>
          <xPosition>17</xPosition>
          <yPosition>41</yPosition>
        </PositionPoints>
        <PositionPoints>
          <xPosition>18</xPosition>
          <yPosition>41</yPosition>
        </PositionPoints>
      </Location>
    </Incident>
  </Outage>
</PubOutages>
```

```

</Incident>
<OutageArea>
  <earliestReportedTime>2019-12-17T09:30:47Z</earliestReportedTime>
  <metersServed>2112</metersServed>
  <outageAreaKind>county</outageAreaKind>
</OutageArea>
</Outage>
</PubOutages>

```

Use Case ODI-ADD-MTO-OA1 (ManyToOne OutageAreas): A POST Request to add Outage Data With Multiple Outage Areas Provided

In this use case, multiple *OutageAreas* are present in a single outage message. Because this is a more general outage message, it likely won't be as detailed as the one in this example. All fields are required in *OutageArea* because of how broad this kind of message is likely to be.

Result Expectation: Outage message is processed successfully with multiple *OutageArea* elements.

```

<?xml version="1.0" encoding="UTF-8"?>
<!--Sample XML file generated by XMLSpy v2018 (x64) (http://www.altova.com)-->
<PubOutages xmlns="http://iec.ch/TC57/2014/PubOutages#"
xmlns:xsi="http://www.w3.org/2001/XMLSchema-instance"
xsi:schemaLocation="http://iec.ch/TC57/2014/PubOutages# PubOutages.xsd">
  <Outage>
    <mRID>1bffe318-6acb-4f21-9753-a8e99247b258</mRID>
    <cause>weather</cause>
    <causeKind>lightingStrike</causeKind>
    <communityDescriptor>Ballard</communityDescriptor>
    <customersRestored>313</customersRestored>
    <metersAffected>477</metersAffected>
    <originalCustomersServed>790</originalCustomersServed>
    <originalMetersAffected>790</originalMetersAffected>
    <outageKind>partiallyRestored</outageKind>
    <reportedStartTime>2019-12-17T09:30:47Z</reportedStartTime>
    <statusKind>fieldComplete</statusKind>
    <utilityDisclaimer>none</utilityDisclaimer>
    <actualPeriod>
      <end>2019-12-17T09:30:47Z</end>
      <start>2019-12-17T09:30:47Z</start>
    </actualPeriod>
    <estimatedPeriod>
      <end>2019-12-17T09:30:47Z</end>
      <start>2019-12-17T09:30:47Z</start>
    </estimatedPeriod>
    <EstimatedRestorationTime>
      <confidenceKind>high</confidenceKind>
      <ert>2019-12-17T09:30:47Z</ert>
      <ertSource>lineman</ertSource>
    </EstimatedRestorationTime>
  <Incident>
    <cause>wind</cause>
    <Location>

```

```

    <direction>S</direction>
    <geoInfoReference>Ballard Locks</geoInfoReference>
    <kind>weatherZone</kind>
    <type>geographical</type>
    <CoordinateSystem>
      <crsUrn>EPSG:4326</crsUrn>
    </CoordinateSystem>
    <PositionPoints>
      <sequenceNumber>0</sequenceNumber>
      <xPosition>17</xPosition>
      <yPosition>31</yPosition>
    </PositionPoints>
  </Location>
</Incident>
<OutageArea>
  <earliestReportedTime>2019-12-17T09:30:47Z</earliestReportedTime>
  <metersServed>120</metersServed>
  <outageAreaKind>borough</outageAreaKind>
</OutageArea>
<OutageArea>
  <earliestReportedTime>2019-12-17T09:30:47Z</earliestReportedTime>
  <metersServed>670</metersServed>
  <outageAreaKind>zipcode</outageAreaKind>
</OutageArea>
</Outage>
</PubOutages>

```

Use Case ODI-ADD-MTO-OA2 (ManyToOne OutageAreas): A POST Request to add Outage Data With Multiple Outage Areas Provided With Missing Mandatory Field

This use case is mostly the same as ODI-ADD-MTO-OA1, except that one of the mandatory fields, `outageAreaKind`, is missing in one of the `OutageAreas`. Despite the rest of the message being well-formed, this causes the entire message to not validate against the schema.

Result Expectation: Message should fail with error code due to missing mandatory attribute `outageAreaKind` in element `OutageArea`.

```

<?xml version="1.0" encoding="UTF-8"?>
<!--Sample XML file generated by XMLSpy v2018 (x64) (http://www.altova.com)-->
<PubOutages xmlns="http://iec.ch/TC57/2014/PubOutages#"
  xmlns:xsi="http://www.w3.org/2001/XMLSchema-instance"
  xsi:schemaLocation="http://iec.ch/TC57/2014/PubOutages# PubOutages.xsd">
  <Outage>
    <mRID>e8fd0dcb-e3fc-4320-a2f5-5761fa1f631d</mRID>
    <cause>weather</cause>
    <causeKind>lightingStrike</causeKind>
    <communityDescriptor>Ballard</communityDescriptor>
    <customersRestored>313</customersRestored>
    <metersAffected>477</metersAffected>
    <originalCustomersServed>790</originalCustomersServed>
    <originalMetersAffected>790</originalMetersAffected>

```

```

<outageKind>partiallyRestored</outageKind>
<reportedStartTime>2019-12-17T09:30:47Z</reportedStartTime>
<statusKind>fieldComplete</statusKind>
<utilityDisclaimer>none</utilityDisclaimer>
<actualPeriod>
  <end>2019-12-17T09:30:47Z</end>
  <start>2019-12-17T09:30:47Z</start>
</actualPeriod>
<estimatedPeriod>
  <end>2019-12-17T09:30:47Z</end>
  <start>2019-12-17T09:30:47Z</start>
</estimatedPeriod>
<EstimatedRestorationTime>
  <confidenceKind>high</confidenceKind>
  <ert>2019-12-17T09:30:47Z</ert>
  <ertSource>lineman</ertSource>
</EstimatedRestorationTime>
<Incident>
  <cause>wind</cause>
  <Location>
    <direction>S</direction>
    <geoInfoReference>Ballard Locks</geoInfoReference>
    <kind>weatherZone</kind>
    <type>geographical</type>
    <CoordinateSystem>
      <crsUrn>EPSG:4326</crsUrn>
    </CoordinateSystem>
    <PositionPoints>
      <sequenceNumber>0</sequenceNumber>
      <xPosition>17</xPosition>
      <yPosition>31</yPosition>
    </PositionPoints>
  </Location>
</Incident>
<OutageArea>
  <earliestReportedTime>2019-12-17T09:30:47Z</earliestReportedTime>
  <metersServed>120</metersServed>
  <outageAreaKind>borough</outageAreaKind>
</OutageArea>
<OutageArea>
  <earliestReportedTime>2019-12-17T09:30:47Z</earliestReportedTime>
  <metersServed>670</metersServed>
</OutageArea>
</Outage>
</PubOutages>

```

Use Case ODI-ADD-MTO-INC1 (ManyToOne Incidents): A POST Request to add Outage Data With Multiple Incidents Provided

In this use case, an outage message is sent with multiple *Incident* elements to describe where outages have occurred in different locations. The receiving system should be able to process multiple *Incidents* for a single outage.

Result Expectation: Outage message is successfully processed with multiple *Incident* elements. Only showing one of the *Incidents* and creating three separate outages or only listing one of the *Incidents* for a single outage message is considered a failure.

```
<?xml version="1.0" encoding="UTF-8"?>
<!--Sample XML file generated by XMLSpy v2018 (x64) (http://www.altova.com)-->
<PubOutages xmlns="http://iec.ch/TC57/2014/PubOutages#"
xmlns:xsi="http://www.w3.org/2001/XMLSchema-instance"
xsi:schemaLocation="http://iec.ch/TC57/2014/PubOutages# PubOutages.xsd">
  <Outage>
    <mRID>77cef885-ec29-41f2-9c98-ed06fb2da84</mRID>
    <cause>weather</cause>
    <causeKind>lightingStrike</causeKind>
    <communityDescriptor>Ballard</communityDescriptor>
    <customersRestored>313</customersRestored>
    <metersAffected>477</metersAffected>
    <originalCustomersServed>790</originalCustomersServed>
    <originalMetersAffected>790</originalMetersAffected>
    <outageKind>partiallyRestored</outageKind>
    <reportedStartTime>2019-12-17T09:30:47Z</reportedStartTime>
    <statusKind>fieldComplete</statusKind>
    <utilityDisclaimer>none</utilityDisclaimer>
    <actualPeriod>
      <end>2019-12-17T09:30:47Z</end>
      <start>2019-12-17T09:30:47Z</start>
    </actualPeriod>
    <estimatedPeriod>
      <end>2019-12-17T09:30:47Z</end>
      <start>2019-12-17T09:30:47Z</start>
    </estimatedPeriod>
    <EstimatedRestorationTime>
      <confidenceKind>high</confidenceKind>
      <ert>2019-12-17T09:30:47Z</ert>
      <ertSource>lineman</ertSource>
    </EstimatedRestorationTime>
    <Incident>
      <cause>wind</cause>
      <Location>
        <direction>S</direction>
        <geoInfoReference>Ballard Locks</geoInfoReference>
        <kind>weatherZone</kind>
        <type>geographical</type>
        <CoordinateSystem>
          <crsUrn>EPSG:4326</crsUrn>
        </CoordinateSystem>
        <PositionPoints>
          <sequenceNumber>0</sequenceNumber>
          <xPosition>17</xPosition>
          <yPosition>31</yPosition>
        </PositionPoints>
      </Location>
    </Incident>
  </Outage>
</PubOutages>
```



```

    </Location>
  </Incident>
<Incident>
  <cause>wind</cause>
  <Location>
    <direction>NW</direction>
    <geoInfoReference>Golden Gardens Park</geoInfoReference>
    <kind>weatherZone</kind>
    <type>geographical</type>
    <CoordinateSystem>
      <crsUrn>EPSG:4326</crsUrn>
    </CoordinateSystem>
    <PositionPoints>
      <sequenceNumber>0</sequenceNumber>
      <xPosition>17</xPosition>
      <yPosition>31</yPosition>
    </PositionPoints>
  </Location>
</Incident>
<OutageArea>
  <earliestReportedTime>2019-12-17T09:30:47Z</earliestReportedTime>
  <metersServed>120</metersServed>
  <outageAreaKind>borough</outageAreaKind>
</OutageArea>
</Outage>
</PubOutages>

```

Use Case ODI-ADD-MTO-INC2 (ManyToOne Incidents): A POST Request to add Outage Data With Multiple Incidents Provided With Missing Field

This use case is mostly the same as ODI-ADD-MTO-INC1, except that one of the mandatory fields, *cause*, is missing in one of the Incidents. Despite the rest of the message being well-formed, this causes the entire message to not validate against the schema.

Result Expectation: Message should fail with error code due to missing mandatory attribute *cause* in element *Incident*.

```

<?xml version="1.0" encoding="UTF-8"?>
<!--Sample XML file generated by XMLSpy v2018 (x64) (http://www.altova.com)-->
<PubOutages xmlns="http://iec.ch/TC57/2014/PubOutages#"
xmlns:xsi="http://www.w3.org/2001/XMLSchema-instance"
xsi:schemaLocation="http://iec.ch/TC57/2014/PubOutages# PubOutages.xsd">
  <Outage>
    <mRID>842d9936-47c8-4258-b1c3-4309056c05c1</mRID>
    <cause>weather</cause>
    <causeKind>lightingStrike</causeKind>
    <communityDescriptor>Ballard</communityDescriptor>
    <customersRestored>313</customersRestored>
    <metersAffected>477</metersAffected>
    <originalCustomersServed>790</originalCustomersServed>
    <originalMetersAffected>790</originalMetersAffected>

```

```
<outageKind>partiallyRestored</outageKind>
<reportedStartTime>2019-12-17T09:30:47Z</reportedStartTime>
<statusKind>fieldComplete</statusKind>
<utilityDisclaimer>none</utilityDisclaimer>
<actualPeriod>
  <end>2019-12-17T09:30:47Z</end>
  <start>2019-12-17T09:30:47Z</start>
</actualPeriod>
<estimatedPeriod>
  <end>2019-12-17T09:30:47Z</end>
  <start>2019-12-17T09:30:47Z</start>
</estimatedPeriod>
<EstimatedRestorationTime>
  <confidenceKind>high</confidenceKind>
  <ert>2019-12-17T09:30:47Z</ert>
  <ertSource>lineman</ertSource>
</EstimatedRestorationTime>
<Incident>
  <cause>wind</cause>
  <Location>
    <direction>S</direction>
    <geoInfoReference>Ballard Locks</geoInfoReference>
    <kind>weatherZone</kind>
    <type>geographical</type>
    <CoordinateSystem>
      <crsUrn>EPSG:4326</crsUrn>
    </CoordinateSystem>
    <PositionPoints>
      <sequenceNumber>0</sequenceNumber>
      <xPosition>17</xPosition>
      <yPosition>31</yPosition>
    </PositionPoints>
  </Location>
</Incident>
<Incident>
  <Location>
    <direction>NW</direction>
    <geoInfoReference>Golden Gardens Park</geoInfoReference>
    <kind>weatherZone</kind>
    <type>geographical</type>
    <CoordinateSystem>
      <crsUrn>EPSG:4326</crsUrn>
    </CoordinateSystem>
    <PositionPoints>
      <sequenceNumber>0</sequenceNumber>
      <xPosition>17</xPosition>
      <yPosition>31</yPosition>
    </PositionPoints>
  </Location>
</Incident>
<OutageArea>
  <earliestReportedTime>2019-12-17T09:30:47Z</earliestReportedTime>
  <metersServed>120</metersServed>
  <outageAreaKind>borough</outageAreaKind>
</OutageArea>
```

```
</Outage>
</PubOutages>
```

PUT Requests

Use Case ODI-UPD-ALL (Update All Fields): A PUT Request Changing Data From ODI-ADD-ALL

PUT requests are similar to the “change” verb in the CIM SOAP standard; it allows you to change an object but all fields must be provided. For example, if *cause* needs to be changed in an Outage message, the full Outage message must be sent with all data fields filled out as they were in the original POST request. The first test case for PUT, ODI-UPD-ALL, takes the message sent in ODI-ADD-ALL and changes the cause from “weather” to “automobile accident.”

```
<?xml version="1.0" encoding="UTF-8"?>
<!--Sample XML file generated by XMLSpy v2018 (x64) (http://www.altova.com)-->
<PubOutages xmlns="http://iec.ch/TC57/2014/PubOutages#"
xmlns:xsi="http://www.w3.org/2001/XMLSchema-instance"
xsi:schemaLocation="http://iec.ch/TC57/2014/PubOutages# PubOutages.xsd">
  <Outage>
    <mRID>3fbbc649-3e42-401b-bbbc-1ab1a1bcbbbe</mRID>
    <cause>automobile accident</cause>
    <causeKind>treeDown</causeKind>
    <communityDescriptor>Karns</communityDescriptor>
    <customersRestored>3</customersRestored>
    <metersAffected>12</metersAffected>
    <originalCustomersServed>12</originalCustomersServed>
    <originalMetersAffected>12</originalMetersAffected>
    <outageKind>partiallyRestored</outageKind>
    <reportedStartTime>2019-12-17T09:30:47Z</reportedStartTime>
    <statusKind>fieldComplete</statusKind>
    <utilityDisclaimer>none</utilityDisclaimer>
    <actualPeriod>
      <end>2019-12-17T09:30:47Z</end>
      <start>2019-12-17T09:30:47Z</start>
    </actualPeriod>
    <estimatedPeriod>
      <end>2019-12-17T09:30:47Z</end>
      <start>2019-12-17T09:30:47Z</start>
    </estimatedPeriod>
    <EstimatedRestorationTime>
      <confidenceKind>high</confidenceKind>
      <ert>2019-12-17T09:30:47Z</ert>
      <ertSource>lineman</ertSource>
    </EstimatedRestorationTime>
    <Incident>
      <cause>wind</cause>
      <Location>
        <direction>NW</direction>
```

```

    <geoInfoReference>ridge</geoInfoReference>
    <kind>weatherZone</kind>
    <type>geographical</type>
    <CoordinateSystem>
      <crsUrn>EPSG:4326</crsUrn>
    </CoordinateSystem>
    <PositionPoints>
      <sequenceNumber>0</sequenceNumber>
      <xPosition>17</xPosition>
      <yPosition>31</yPosition>
    </PositionPoints>
  </Location>
</Incident>
<OutageArea>
  <earliestReportedTime>2019-12-17T09:30:47Z</earliestReportedTime>
  <metersServed>12</metersServed>
  <outageAreaKind>county</outageAreaKind>
</OutageArea>
</Outage>
</PubOutages>

```

Use Case ODI-UPD-OPT-AP1 (Update Optional ActualPeriod): A PUT Request to Change ODI-ADD-OPT-AP1 by Adding Actualperiod Data

This request takes the ODI-ADD-OPT-AP1 message and adds in the missing data for Actualperiod before resending. Therefore, it uses the same mRID as ODI-ADD-OPT-AP1. All data should otherwise remain the same as in ODI-ADD-OPT-AP1.

Result Expectation: A successfully changed outage message for outage with mRID fc9758b7-d121-4233-b9f0-a63f288143fa. The *actualPeriod* element should now be present.

```

<?xml version="1.0" encoding="UTF-8"?>
<PubOutages xmlns="http://iec.ch/TC57/2014/PubOutages#"
xmlns:xsi="http://www.w3.org/2001/XMLSchema-instance"
xsi:schemaLocation="http://iec.ch/TC57/2014/PubOutages# PubOutages.xsd">
  <Outage>
    <mRID>fc9758b7-d121-4233-b9f0-a6ef288143fa</mRID>
    <cause>auto accident</cause>
    <causeKind>treeDown</causeKind>
    <communityDescriptor>Bellevue</communityDescriptor>
    <customersRestored>5</customersRestored>
    <metersAffected>107</metersAffected>
    <originalCustomersServed>112</originalCustomersServed>
    <originalMetersAffected>112</originalMetersAffected>
    <outageKind>partiallyRestored</outageKind>
    <reportedStartTime>2019-12-17T09:30:47Z</reportedStartTime>
    <statusKind>fieldComplete</statusKind>
    <utilityDisclaimer>none</utilityDisclaimer>
    <actualPeriod>

```

```

    <end>2019-12-17T09:30:47Z</end>
    <start>2019-12-17T10:30:47Z</start>
  </actualPeriod>
  <estimatedPeriod>
    <end>2019-12-17T09:30:47Z</end>
    <start>2019-12-17T09:30:47Z</start>
  </estimatedPeriod>
  <EstimatedRestorationTime>
    <confidenceKind>high</confidenceKind>
    <ert>2019-12-17T09:30:47Z</ert>
    <ertSource>control center</ertSource>
  </EstimatedRestorationTime>
  <Incident>
    <cause>wind</cause>
    <Location>
      <direction>NW</direction>
      <geoInfoReference>lake</geoInfoReference>
      <kind>weatherZone</kind>
      <type>geographical</type>
      <CoordinateSystem>
        <crsUrn>EPSG:4326</crsUrn>
      </CoordinateSystem>
      <PositionPoints>
        <sequenceNumber>0</sequenceNumber>
        <xPosition>33</xPosition>
        <yPosition>15</yPosition>
      </PositionPoints>
    </Location>
  </Incident>
  <OutageArea>
    <earliestReportedTime>2019-12-17T09:30:47Z</earliestReportedTime>
    <metersServed>112</metersServed>
    <outageAreaKind>county</outageAreaKind>
  </OutageArea>
</Outage>
</PubOutages>

```

Use Case ODI-UPD-OPT-EP1 (Update Optional EstimatedPeriod): A POST Request to Change ODI-ADD-OPT-EP1 by Adding Estimatedperiod Data

This request takes the ODI-ADD-OPT-EP1 message and adds in the missing data for estimatedPeriod before resending. It uses the same mRID as ODI-ADD-OPT-EP1. All data should otherwise remain the same as in ODI-ADD-OPT-EP1.

Result Expectation: A successfully changed outage message for outage with mRID fd532f2d-37d8-423a-a08e-8f9e4c4e6283. The *estimatedPeriod* element should now be present.

```
<?xml version="1.0" encoding="UTF-8"?>
```

```
<PubOutages xmlns="http://iec.ch/TC57/2014/PubOutages#"
xmlns:xsi="http://www.w3.org/2001/XMLSchema-instance"
xsi:schemaLocation="http://iec.ch/TC57/2014/PubOutages# PubOutages.xsd">
  <Outage>
    <mRID>fd532f2d-37d8-423a-a08e-8f9e4c4e6283</mRID>
    <cause>animal</cause>
    <causeKind>poleDown</causeKind>
    <communityDescriptor>Belltown</communityDescriptor>
    <customersRestored>177</customersRestored>
    <metersAffected>835</metersAffected>
    <originalCustomersServed>1012</originalCustomersServed>
    <originalMetersAffected>1012</originalMetersAffected>
    <outageKind>partiallyRestored</outageKind>
    <reportedStartTime>2019-12-17T09:30:47Z</reportedStartTime>
    <statusKind>arrived</statusKind>
    <utilityDisclaimer>none</utilityDisclaimer>
    <actualPeriod>
      <end>2019-12-17T09:30:47Z</end>
      <start>2019-12-17T09:30:47Z</start>
    </actualPeriod>
    <estimatedPeriod>
      <end>2019-12-17T09:30:47Z</end>
      <start>2019-12-17T09:30:47Z</start>
    </estimatedPeriod>
    <EstimatedRestorationTime>
      <confidenceKind>high</confidenceKind>
      <ert>2019-12-17T09:30:47Z</ert>
      <ertSource>control center</ertSource>
    </EstimatedRestorationTime>
    <Incident>
      <cause>wind</cause>
      <Location>
        <direction>W</direction>
        <geoInfoReference>park</geoInfoReference>
        <kind>weatherZone</kind>
        <type>geographical</type>
        <CoordinateSystem>
          <crsUrn>EPSG:4326</crsUrn>
        </CoordinateSystem>
        <PositionPoints>
          <sequenceNumber>0</sequenceNumber>
          <xPosition>15</xPosition>
          <yPosition>66</yPosition>
        </PositionPoints>
      </Location>
    </Incident>
    <OutageArea>
      <earliestReportedTime>2019-12-17T09:30:47Z</earliestReportedTime>
      <metersServed>1012</metersServed>
      <outageAreaKind>county</outageAreaKind>
    </OutageArea>
  </Outage>
</PubOutages>
```

Use Case ODI-UPD-OPT-ERT1 (Update Optional EstimatedRestorationTime): A PUT Request to Change ODI-ADD-OPT-ERT1 by Adding EstimatedRestorationTime

This request takes the ODI-ADD-OPT-ERT1 message and adds in the missing data for estimatedRestorationTime before resending. It uses the same mRID as ODI-ADD-OPT-ERT1. All data should otherwise remain the same as in ODI-ADD-OPT-ERT1.

Result Expectation: A successfully changed outage message for outage with mRID 18ea4e83-296a-4f33-a07c-6fbfa4ec777b. The *EstimatedRestorationTime* element should now be present.

```
<?xml version="1.0" encoding="UTF-8"?>
<PubOutages xmlns="http://iec.ch/TC57/2014/PubOutages#"
xmlns:xsi="http://www.w3.org/2001/XMLSchema-instance"
xsi:schemaLocation="http://iec.ch/TC57/2014/PubOutages# PubOutages.xsd">
  <Outage>
    <mRID>18ea4e83-296a-4f33-a07c-6fbfa4ec777b</mRID>
    <cause>tree</cause>
    <causeKind>lineDown</causeKind>
    <communityDescriptor>Bainbridge Island</communityDescriptor>
    <customersRestored>17</customersRestored>
    <metersAffected>35</metersAffected>
    <originalCustomersServed>52</originalCustomersServed>
    <originalMetersAffected>52</originalMetersAffected>
    <outageKind>partiallyRestored</outageKind>
    <reportedStartTime>2019-12-17T09:30:47Z</reportedStartTime>
    <statusKind>arrived</statusKind>
    <utilityDisclaimer>none</utilityDisclaimer>
    <actualPeriod>
      <end>2019-12-17T09:30:47Z</end>
      <start>2019-12-17T09:30:47Z</start>
    </actualPeriod>
    <estimatedPeriod>
      <end>2019-12-17T09:30:47Z</end>
      <start>2019-12-17T09:30:47Z</start>
    </estimatedPeriod>
    <EstimatedRestorationTime>
      <confidenceKind>high</confidenceKind>
      <ert>2019-12-17T09:30:47Z</ert>
      <ertSource>control center</ertSource>
    </EstimatedRestorationTime>
    <Incident>
      <cause>wind</cause>
      <Location>
        <direction>S</direction>
        <geoInfoReference>campground</geoInfoReference>
        <kind>weatherZone</kind>
        <type>geographical</type>
        <CoordinateSystem>
          <crsUrn>EPSG:4326</crsUrn>
        </CoordinateSystem>
      </Location>
    </Incident>
  </Outage>
</PubOutages>
```

```

    <PositionPoints>
      <sequenceNumber>0</sequenceNumber>
      <xPosition>24</xPosition>
      <yPosition>11</yPosition>
    </PositionPoints>
  </Location>
</Incident>
<OutageArea>
  <earliestReportedTime>2019-12-17T09:30:47Z</earliestReportedTime>
  <metersServed>52</metersServed>
  <outageAreaKind>county</outageAreaKind>
</OutageArea>
</Outage>
</PubOutages>

```

Use Case ODI-UPD-MTO-PP1 (Update Multiple PositionPoints): A PUT Request to Change ODI-ADD-MTO-PP1 by Removing Extra PositionPoints

This request takes the ODI-ADD-MTO-PP1 message and removes the additional PositionPoints aside from the first one. It uses the same mRID as ODI-ADD-MTO-PP1. All data should otherwise remain the same as in ODI-ADD-MTO-PP1.

Result Expectation: A successfully changed outage message for outage with mRID 65c8eee7-1ccc-4229-a03e-18196516ae03. The *PositionPoints* element should only show one instead of many *PositionPoints*.

```

<?xml version="1.0" encoding="UTF-8"?>
<!--Sample XML file generated by XMLSpy v2018 (x64) (http://www.altova.com)-->
<PubOutages xmlns="http://iec.ch/TC57/2014/PubOutages#"
xmlns:xsi="http://www.w3.org/2001/XMLSchema-instance"
xsi:schemaLocation="http://iec.ch/TC57/2014/PubOutages# PubOutages.xsd">
  <Outage>
    <mRID>65c8eee7-1ccc-4229-a03e-18196516ae03</mRID>
    <cause>weather</cause>
    <causeKind>poleDown</causeKind>
    <communityDescriptor>downtown</communityDescriptor>
    <customersRestored>1700</customersRestored>
    <metersAffected>2112</metersAffected>
    <originalCustomersServed>1272</originalCustomersServed>
    <originalMetersAffected>2112</originalMetersAffected>
    <outageKind>partiallyRestored</outageKind>
    <reportedStartTime>2019-12-17T09:30:47Z</reportedStartTime>
    <statusKind>fieldComplete</statusKind>
    <utilityDisclaimer>none</utilityDisclaimer>
    <actualPeriod>
      <end>2019-12-17T09:30:47Z</end>
      <start>2019-12-17T09:30:47Z</start>
    </actualPeriod>
    <estimatedPeriod>
      <end>2019-12-17T09:30:47Z</end>
      <start>2019-12-17T09:30:47Z</start>

```



```

</estimatedPeriod>
<EstimatedRestorationTime>
  <confidenceKind>high</confidenceKind>
  <ert>2019-12-17T09:30:47Z</ert>
  <ertSource>lineman</ertSource>
</EstimatedRestorationTime>
<Incident>
  <cause>wind</cause>
  <Location>
    <direction>NW</direction>
    <geoInfoReference>ridge</geoInfoReference>
    <kind>weatherZone</kind>
    <type>geographical</type>
    <CoordinateSystem>
      <crsUrn>EPSG:4326</crsUrn>
    </CoordinateSystem>
    <PositionPoints>
      <sequenceNumber>0</sequenceNumber>
      <xPosition>17</xPosition>
      <yPosition>31</yPosition>
    </PositionPoints>
  </Location>
</Incident>
<OutageArea>
  <earliestReportedTime>2019-12-17T09:30:47Z</earliestReportedTime>
  <metersServed>2112</metersServed>
  <outageAreaKind>county</outageAreaKind>
</OutageArea>
</Outage>
</PubOutages>

```

Use Case ODI-UPD-MTO-OA1 (Update Multiple OutageAreas): A PUT Request to Change ODI-ADD-MTO-OA1 by Removing Extra OutageAreas

Like ODI-UPD-MTO-PP1, this use case removes the additional outage areas listed by message ODI-ADD-MTO-OA1.

Result Expectation: A successfully changed outage message for outage with mRID 1bffe318-6acb-4f21-9753-a8e99247b258. The *OutageArea* element should only show one instead of many *OutageAreas*.

```

<?xml version="1.0" encoding="UTF-8"?>
<!--Sample XML file generated by XMLSpy v2018 (x64) (http://www.altova.com)-->
<PubOutages xmlns="http://iec.ch/TC57/2014/PubOutages#"
xmlns:xsi="http://www.w3.org/2001/XMLSchema-instance"
xsi:schemaLocation="http://iec.ch/TC57/2014/PubOutages# PubOutages.xsd">
  <Outage>
    <mRID>1bffe318-6acb-4f21-9753-a8e99247b258</mRID>
    <cause>weather</cause>
    <causeKind>lightingStrike</causeKind>
    <communityDescriptor>Ballard</communityDescriptor>

```

```

<customersRestored>313</customersRestored>
<metersAffected>477</metersAffected>
<originalCustomersServed>790</originalCustomersServed>
<originalMetersAffected>790</originalMetersAffected>
<outageKind>partiallyRestored</outageKind>
<reportedStartTime>2019-12-17T09:30:47Z</reportedStartTime>
<statusKind>fieldComplete</statusKind>
<utilityDisclaimer>none</utilityDisclaimer>
<actualPeriod>
  <end>2019-12-17T09:30:47Z</end>
  <start>2019-12-17T09:30:47Z</start>
</actualPeriod>
<estimatedPeriod>
  <end>2019-12-17T09:30:47Z</end>
  <start>2019-12-17T09:30:47Z</start>
</estimatedPeriod>
<EstimatedRestorationTime>
  <confidenceKind>high</confidenceKind>
  <ert>2019-12-17T09:30:47Z</ert>
  <ertSource>lineman</ertSource>
</EstimatedRestorationTime>
<Incident>
  <cause>wind</cause>
  <Location>
    <direction>S</direction>
    <geoInfoReference>Ballard Locks</geoInfoReference>
    <kind>weatherZone</kind>
    <type>geographical</type>
    <CoordinateSystem>
      <crsUrn>EPSG:4326</crsUrn>
    </CoordinateSystem>
    <PositionPoints>
      <sequenceNumber>0</sequenceNumber>
      <xPosition>17</xPosition>
      <yPosition>31</yPosition>
    </PositionPoints>
  </Location>
</Incident>
<OutageArea>
  <earliestReportedTime>2019-12-17T09:30:47Z</earliestReportedTime>
  <metersServed>120</metersServed>
  <outageAreaKind>borough</outageAreaKind>
</OutageArea>
</Outage>
</PubOutages>

```

Use Case ODI-UPD-MTO-INC1 (Update ManyToOne Incidents): A PUT Request to Change ODI-ADD-MTO-INC1 by Removing Extra Incidents

This use case removes additional Incident fields from the ODI-ADD-MTO-INC1 message. This message should be mostly identical to ODI-ADD-MTO-INC1 except for the additional Incident fields.

Result Expectation: A successfully changed outage message for outage with mRID 77cef885-ec29-41f2-9c98-ede06fb2da84. The *Incident* element should only show one instead of many *Incidents*.

```
<?xml version="1.0" encoding="UTF-8"?>
<!--Sample XML file generated by XMLSpy v2018 (x64) (http://www.altova.com)-->
<PubOutages xmlns="http://iec.ch/TC57/2014/PubOutages#"
xmlns:xsi="http://www.w3.org/2001/XMLSchema-instance"
xsi:schemaLocation="http://iec.ch/TC57/2014/PubOutages# PubOutages.xsd">
  <Outage>
    <mRID>77cef885-ec29-41f2-9c98-ede06fb2da84</mRID>
    <cause>weather</cause>
    <causeKind>lightingStrike</causeKind>
    <communityDescriptor>Ballard</communityDescriptor>
    <customersRestored>313</customersRestored>
    <metersAffected>477</metersAffected>
    <originalCustomersServed>790</originalCustomersServed>
    <originalMetersAffected>790</originalMetersAffected>
    <outageKind>partiallyRestored</outageKind>
    <reportedStartTime>2019-12-17T09:30:47Z</reportedStartTime>
    <statusKind>fieldComplete</statusKind>
    <utilityDisclaimer>none</utilityDisclaimer>
    <actualPeriod>
      <end>2019-12-17T09:30:47Z</end>
      <start>2019-12-17T09:30:47Z</start>
    </actualPeriod>
    <estimatedPeriod>
      <end>2019-12-17T09:30:47Z</end>
      <start>2019-12-17T09:30:47Z</start>
    </estimatedPeriod>
    <EstimatedRestorationTime>
      <confidenceKind>high</confidenceKind>
      <ert>2019-12-17T09:30:47Z</ert>
      <ertSource>lineman</ertSource>
    </EstimatedRestorationTime>
    <Incident>
      <cause>wind</cause>
      <Location>
        <direction>S</direction>
        <geoInfoReference>Ballard Locks</geoInfoReference>
        <kind>weatherZone</kind>
        <type>geographical</type>
        <CoordinateSystem>
          <crsUrn>EPSG:4326</crsUrn>
        </CoordinateSystem>
        <PositionPoints>
          <sequenceNumber>0</sequenceNumber>
          <xPosition>17</xPosition>
          <yPosition>31</yPosition>
        </PositionPoints>
      </Location>
    </Incident>
    <OutageArea>
      <earliestReportedTime>2019-12-17T09:30:47Z</earliestReportedTime>
      <metersServed>120</metersServed>
      <outageAreaKind>borough</outageAreaKind>
    </OutageArea>
  </Outage>
</PubOutages>
```

```
</OutageArea>
</Outage>
</PubOutages>
```

PATCH Requests

Use Case ODI-PATCH-1FIELD (Patch One Field): A PATCH Request to Change One Mislabeled Field from ODI-ADD-ALL

In this request, we are modifying the *cause field* via PATCH request. Unlike a PUT request, only the field being changed needs to reply, being sent to a URL corresponding to the object being modified. A sample URL to send ODI-PATCH-1FIELD would be <http://myservice.com/odi/3fbbc649-3e42-401b-bbbc-1ab1a1bcbbbe> and the message would be a short XML as shown below.

Result Expectation: Outage with mRID 3fbbc649-3e42-401b-bbbc-1ab1a1bcbbbe should be the same as it was prior to this call with the exception of the *cause* field being changed.

```
<?xml version="1.0" encoding="UTF-8"?>
<PubOutages xmlns="http://iec.ch/TC57/2014/PubOutages#">
  <Outage>
    <cause>high winds</cause>
  </Outage>
</PubOutages>
```

Get Requests

Use Case ODI-GET-ALL (Get All Outages): A GET Request to Retrieve All Outage Data

This use case is a simple GET request to retrieve all Outage information. Send a GET message to your web service's URL, for example, <http://mywebservice.com/odi>.

Result Expectation: All current outages should be retrieved when this message is called.

Use Case ODI-GET-ONE (Get Specified Outage): A GET Request to Retrieve Specific Outage Data

This use case makes use of the mRID to retrieve data for a specific Outage. In SOAP UI, multiple parameters can be set for each message. To retrieve data based on mRID if it's not being used as the database primary key, an example parameter would be set like pictured below:

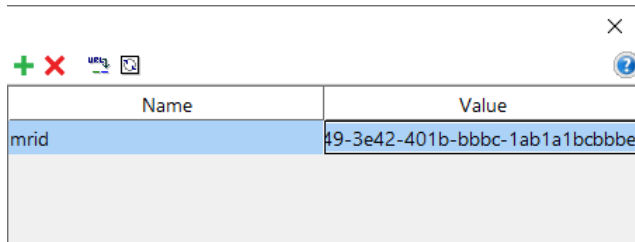

Figure 11: Setting optional parameters for a RESTful URI in SoapUI

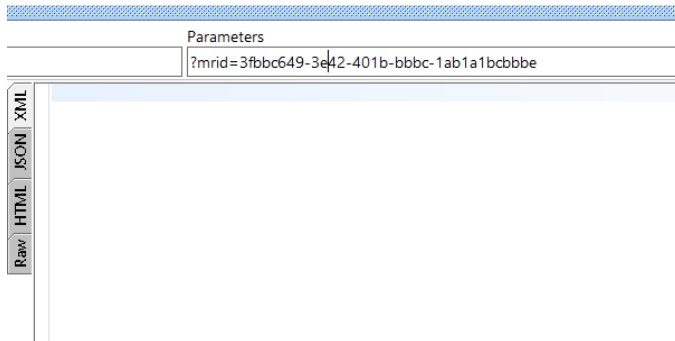

Figure 12: View of all added parameters in a RESTful URI in SoapUI

Note that many REST APIs use an integer field instead of UUID for indexing the database. In that case, either option could be used for retrieval of data, but it is considered good practice to keep your actual primary key of each object hidden from users and have them use a mRID to obtain the object instead.

For the purposes of this test script, the assumption is that the mRID will be used to retrieve an Outage object. For this case then, a message would be sent to <http://mywebservice.com/odi/3fbbc649-3e42-401b-bbbc-1ab1a1bcbbbe>.

Result Expectation: Only the outage data for outage with mRID 3fbbc649-3e42-401b-bbbc-1ab1a1bcbbbe should be retrieved.

Use Case ODI-DEL-ONE (Delete Outage): A DELETE Request to Remove Outage Data Created Earlier

Should an Outage need to be cleared for any reason, the DELETE verb must be used to delete the object. This use case deletes the outage that was just updated in PATCH7 (created originally in ODI-ADD-ALL). There is no sample XML for this. Simply send a DELETE message to <http://mywebservice.com/odi/3fbbc649-3e42-401b-bbbc-1ab1a1bcbbbe> and verify via GET that the Outage has been deleted.

Result Expectation: Only the outage with mRID 3fbbc649-3e42-401b-bbbc-1ab1a1bcbbbe should be deleted.